

LOC		DIST		REVISIONS			
P	LTR	DESCRIPTION	DATE	DWN	APVD		
B		PER EC 0514-0184-04	12JAN05	BM	JL		

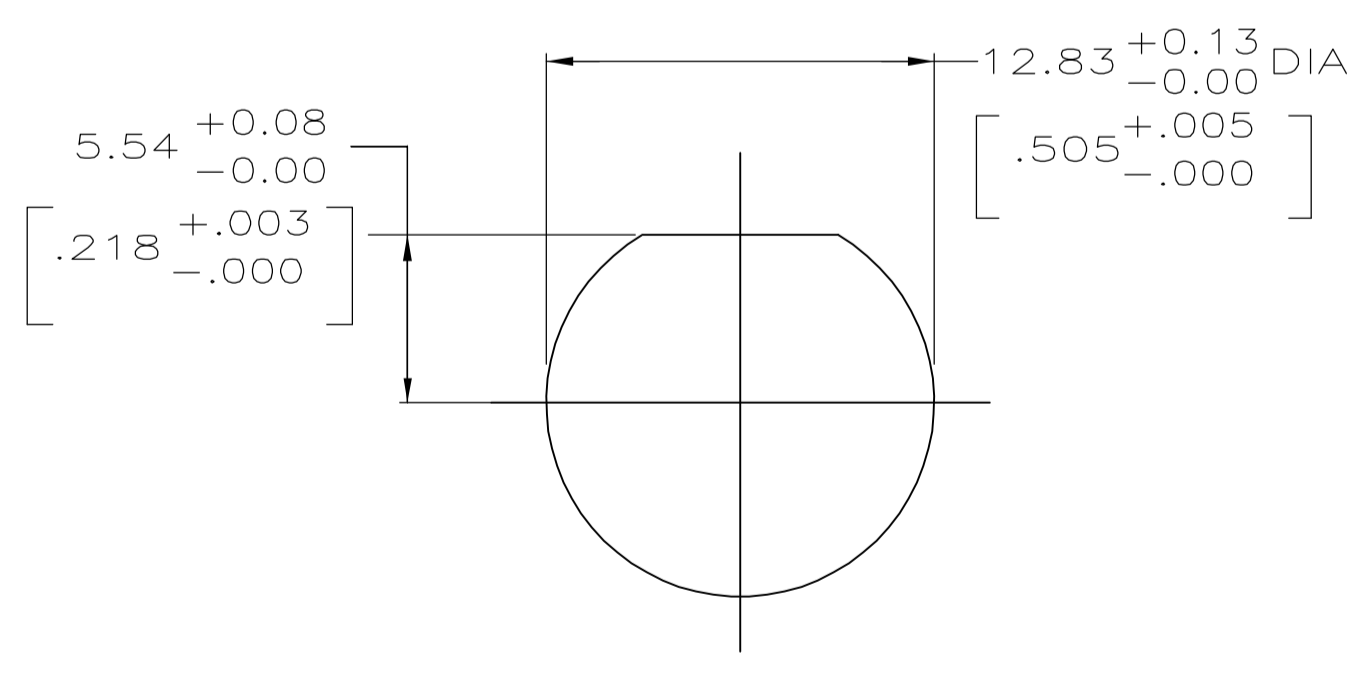

RECOMMENDED PANEL CUTOUT

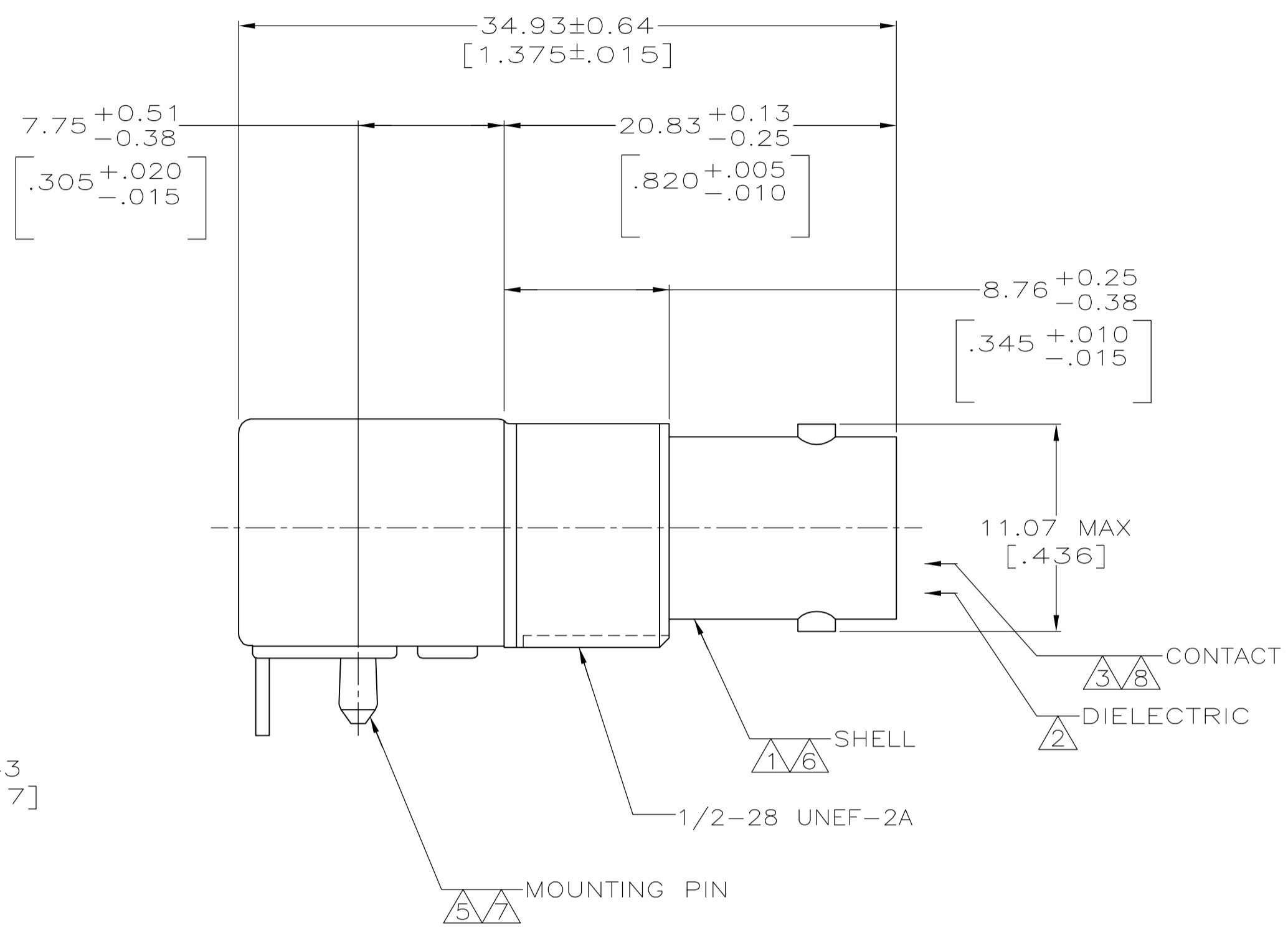
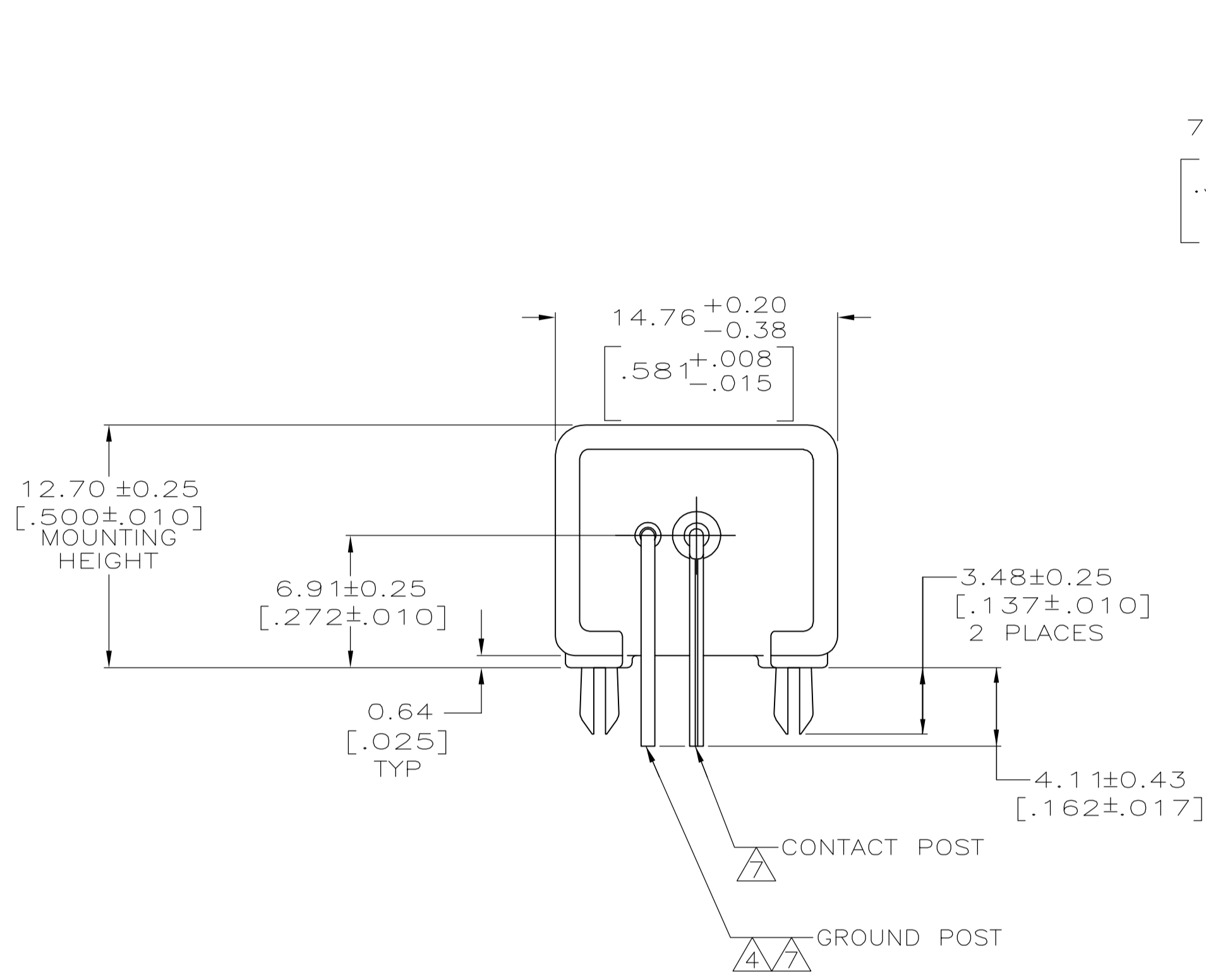
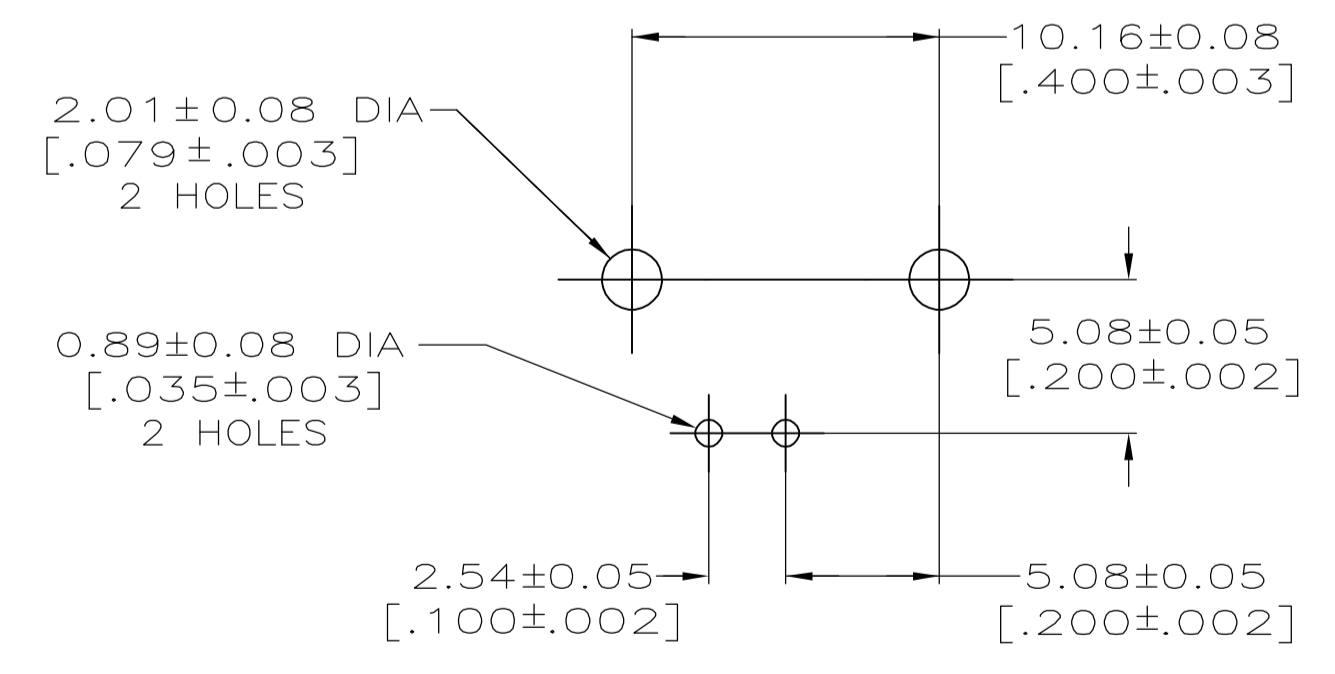

PCB CONFIGURATION

- ① ZINC PER QQ-Z-363.
- ② POLYMETHYLPENTENE PER ASTM-D-1238.
- ③ PHOSPHOR BRONZE PER QQ-B-750.
- ④ BRASS PER ASTM-B-453.
- ⑤ BRASS PER ASTM-B-16.
- ⑥ NICKEL PLATE PER QQ-N-290, 3.81 μm [.000150] MINIMUM THICK.
- ⑦ TIN PLATE PER ASTM B 545, 3.81 μm [.000150] MINIMUM THICK.
- ⑧ GOLD PLATE PER MIL-G-45204, 0.76 μm [.000030] MINIMUM THICK.
- ⑨ USE INSTRUCTION SHEET 2769.

415417-1
PART NUMBER

THIS DRAWING IS A CONTROLLED DOCUMENT.		DWN MICHAEL E. COWHER 15MAY96	Tyco Electronics Corporation Harrisburg, PA 17105-3608	
DIMENSIONS: mm [inches]		CHK MICHAEL J. TOMCHAK 15MAY96	NAME MICHAEL J. TOMCHAK 15MAY96	
TOLERANCES UNLESS OTHERWISE SPECIFIED:		PRODUCT SPEC 108-12078		
0 PLC ± -		APPLICATION SPEC		
1 PLC ± -		SIZE A1		
2 PLC ± -		CAGE CODE 00779		
3 PLC ± -		DRAWING NO 415417		
4 PLC ± -		RESTRICTED TO		
ANGLES ± ±		WEIGHT		
FINISH SEE NOTES		CUSTOMER DRAWING		
SCALE 4:1		SHEET 1 OF 1		
		REV B		